

1160B-FPA1

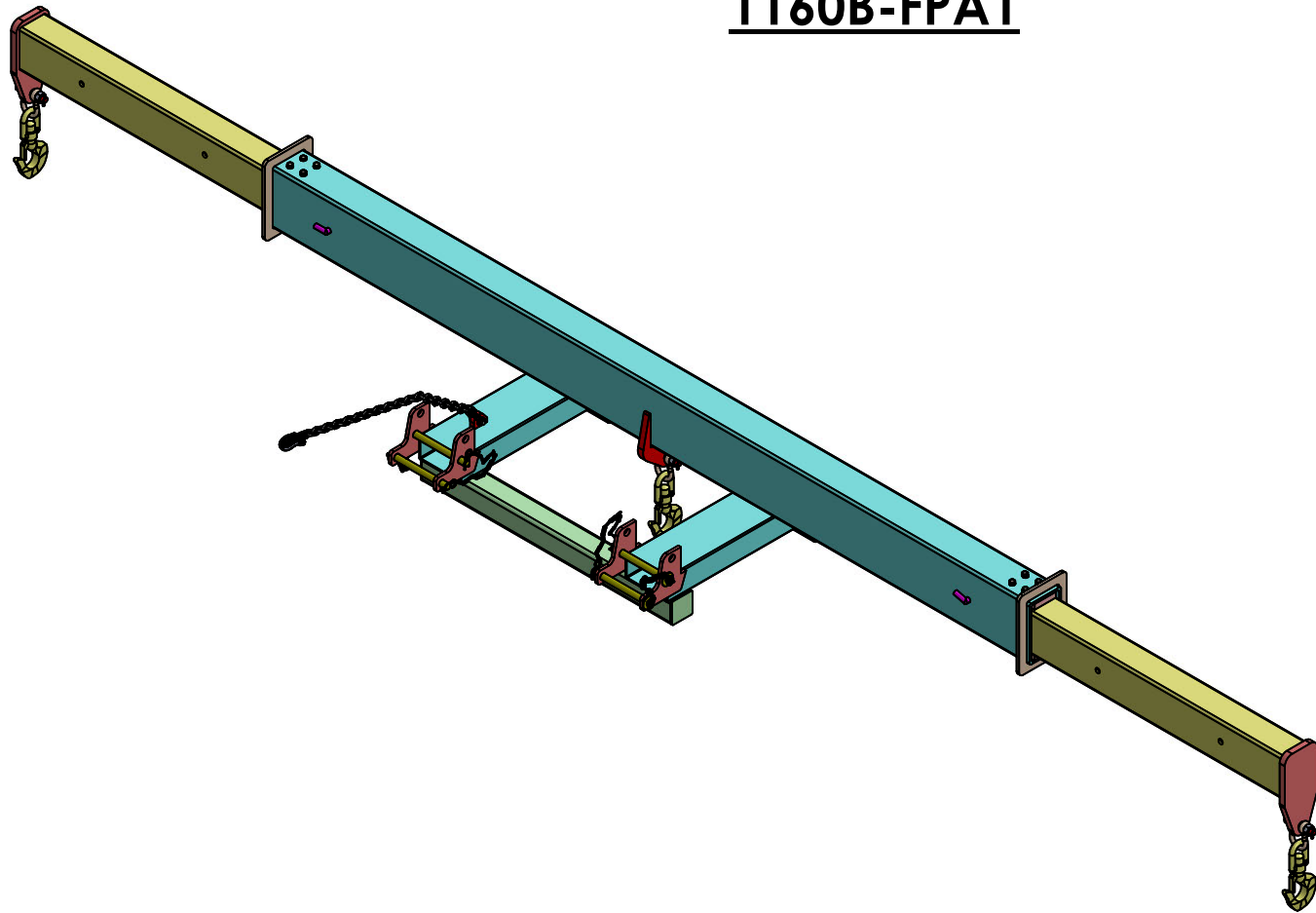

PROPRIETARY AND CONFIDENTIAL
 THE INFORMATION CONTAINED IN THIS DRAWING IS THE SOLE PROPERTY OF STAR INDUSTRIES. ANY REPRODUCTION IN PART OR AS A WHOLE WITHOUT THE WRITTEN PERMISSION OF STAR INDUSTRIES IS PROHIBITED.

UNLESS OTHERWISE SPECIFIED:

DIMENSIONS ARE IN INCHES
 TOLERANCES: $\pm 1/16$
 FRACTIONAL \pm
 ANGULAR: MACH \pm BEND \pm
 TWO PLACE DECIMAL \pm
 THREE PLACE DECIMAL \pm

INTERPRET GEOMETRIC TOLERANCING PER:

MATERIAL
 REFER PARTS DETAILS
 FINISH

DO NOT SCALE DRAWING

	NAME	DATE
DRAWN	HI-TECH	4/18/2019
CHECKED		
ENG APPR.		
MFG APPR.		
Q.A.		

COMMENTS:



STAR INDUSTRIES

TITLE:

1160B-FPA1

SIZE A	DWG. NO. 1160B-FPA1 REPLACEABLE PARTS	REV 0
SCALE: 1:25	WEIGHT: 1173.66 LBS	SHEET 1 OF 2

Note:- Item number 5 (Safety Chain Assembly) is combination of items 6, 7, & 8

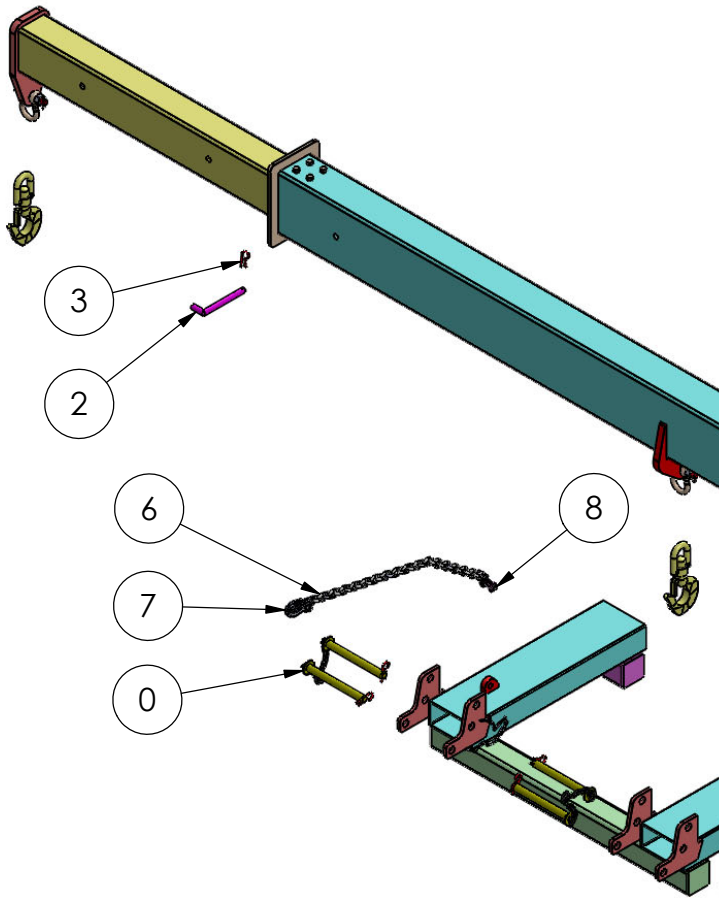

BOM TABLE

ITEM NO.	PART NUMBER	DESCRIPTION	QTY.
1	1000-0260	5 TON SWIVEL HOOK W/LATCH	3
2	1000-0101	6 3/4" X 3/4" LOCKING PIN	2
3	1000-0109	HAIR PIN 3.5" X 0.177" DIA.	2
4	1000-0231	3/4"- 7 TON BOLTED ANCHOR SHACKLE	3
5	1000-0115	SAFETY CHAIN ASSEMBLY WITH CLEVIS LINK	1
6	1000-1600	5/16" X36" GRADE 100 CHAIN	1
7	1000-0240TL	TWIST LOCK GR 80 GRAB HOOK FOR 5/16" CHAIN	1
8	1000-0225	5/16-3/8 DOUBLE CLEVIS LINK S247 5400 LB CAP	1
9	FPA1-1160B-01 ASSLY	FORK CHANNEL ASSY	2
10	100-002	4"X8"X1/4" X32" TUBE	1
11	100-001	8.25"X7"X0.50" PLATE PLASMA CUT	2
12	FPA1-02	4"X4"X1/4"X 47"L TUBE W/ END CAPS	1
13		TS4X4X0.25	47
14			2
15	100-003	CHAIN ANCHOR BLOCK 3/4" PLATE	1
16	100-004	4"X4"X1/4"X 8" TUBE W/ END CAPS	2
17		TS4X4X0.25	8
18			2
19	1000-0108DBL	DUAL 10 1/4" X 1" LOCKING PINS W/CHAINS	2
20	1000-0108	FORK PIN WITH WASHER HAIR PIN	2
21	1000-0108A	10 1/4" X 1" LOCKING PIN ROD	1
22	1000-0108B	PIN CAP	1

UNLESS OTHERWISE SPECIFIED:		NAME	DATE
DIMENSIONS ARE IN INCHES	1000-0109	DRAWN	HI-TECH 4/18/2019
TOLERANCES: ±1/16		CHECKED	
FRACTIONAL ±		ENG APPR.	
ANGULAR: MACH ± BEND ±		MFG APPR.	
TWO PLACE DECIMAL ±		G.A.	
THREE PLACE DECIMAL ±		COMMENTS:	
INTERPRET GEOMETRIC TOLERANCING PER:	1000-0204		
MATERIAL			
REFER PARTS DETAILS			
FINISH			
DO NOT SCALE DRAWING			



STAR INDUSTRIES

5/16" CHAIN LINK

3/16" CHAIN

#4 STRAIGHT LINK CHAIN

SIZE DWG. NO. REV

A 1160B-FPA1 0

REPLACEABLE PARTS

SCALE: 1:25 WEIGHT: 1173.66 LBS SHEET 2 OF 2

PROPRIETARY AND CONFIDENTIAL
 THE INFORMATION CONTAINED IN THIS DRAWING IS THE SOLE PROPERTY OF STAR INDUSTRIES. ANY REPRODUCTION IN PART OR AS A WHOLE WITHOUT THE WRITTEN PERMISSION OF STAR INDUSTRIES IS PROHIBITED.