

5

4

3

2

1

# 1150C-FPA1

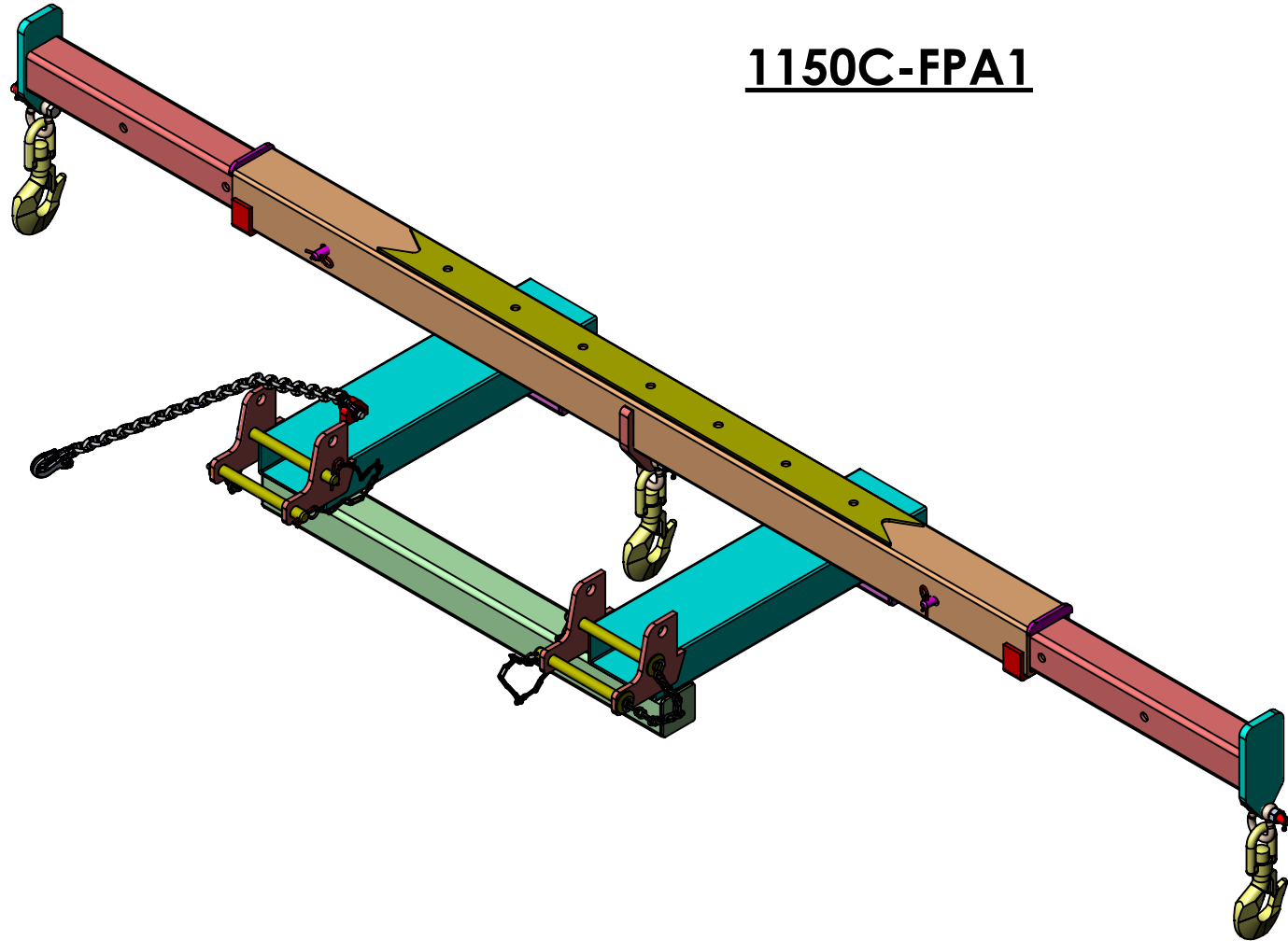

D

D

C

C

B

B

A

A

**PROPRIETARY AND CONFIDENTIAL**  
 THE INFORMATION CONTAINED IN THIS DRAWING IS THE SOLE PROPERTY OF STAR INDUSTRIES. ANY REPRODUCTION IN PART OR AS A WHOLE WITHOUT THE WRITTEN PERMISSION OF STAR INDUSTRIES IS PROHIBITED.

UNLESS OTHERWISE SPECIFIED:	NAME	DATE
DIMENSIONS ARE IN INCHES TOLERANCES: ±1/16	DRAWN HI-TECH	4/17/2019
FRACTIONAL ±	CHECKED	
ANGULAR: MACH ± BEND ±	ENG APPR.	
TWO PLACE DECIMAL ±	MFG APPR.	
THREE PLACE DECIMAL ±	Q.A.	
INTERPRET GEOMETRIC TOLERANCING PER:	COMMENTS:	
MATERIAL REFER PARTS DETAILS		
FINISH		
DO NOT SCALE DRAWING		



**TITLE:**  
 1150C-FPA1

SIZE	DWG. NO.	REV
<b>A</b>	1150C-FPA1-REPLACEABLE PARTS	<b>0</b>
SCALE: 1:15	WEIGHT: 580.42 LBS	SHEET 1 OF 2

Note:- Item number 7 (Safety chain assembly) is combination of items 8, 9 & 10.

ITEM NO.	PART NUMBER	DESCRIPTION	QTY.
1	1000-0232	5/8"- 3 TON BOLTED ANCHOR SHACKLE	3
2	1000-0250	3 TON SWVL HOOK W/LATCH	3
3	1000-0101	6 3/4" X 3/4" LOCKING PIN	2
4	1000-0109	HAIR PIN 3.5" X 0.177" DIA.	2
5	1000-0108DBL	DUAL 10 1/4" X 1" LOCKING PINS W/CHAINS	2
6	1000-0204A	#4 STRAIGHT LINK CHAIN	2
7	1000-0115	SAFETY CHAIN ASSEMBLY WITH CLEVIS LINK	1
8	1000-1600	5/16" X36" GRADE 100 CHAIN	1
9	1000-0240TL	TWIST LOCK GR 80 GRAB HOOK FOR 5/16" CHAIN	1
10	1000-0225	5/16-3/8 DOUBLE CLEVIS LINK S247 5400 LB CAP	1

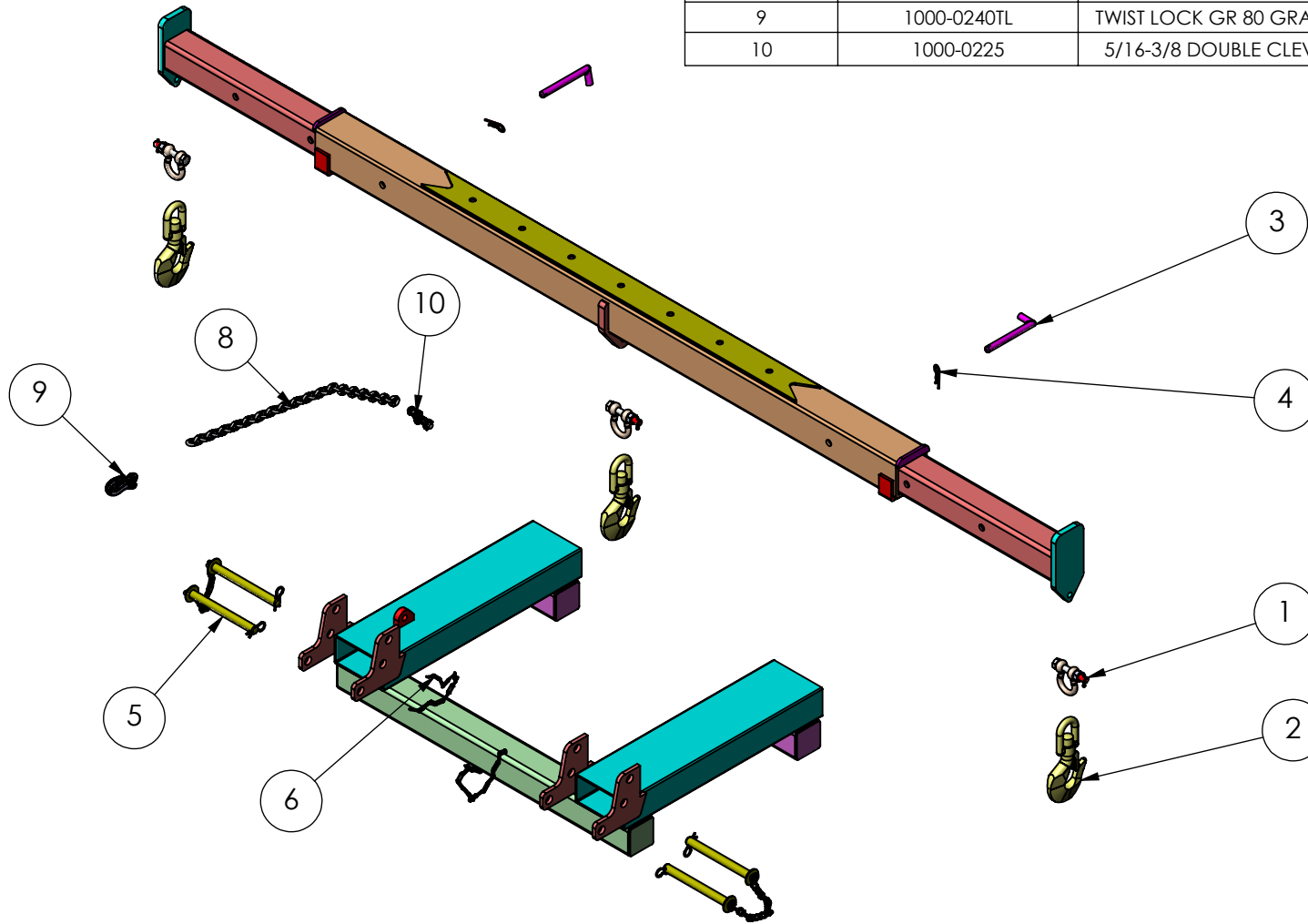

SIZE <b>A</b>	DWG. NO. 1150C-FPA1- REPLACEABLE PARTS	REV <b>0</b>
SCALE: 1:20	WEIGHT: 580.42 LBS	SHEET 2 OF 2