

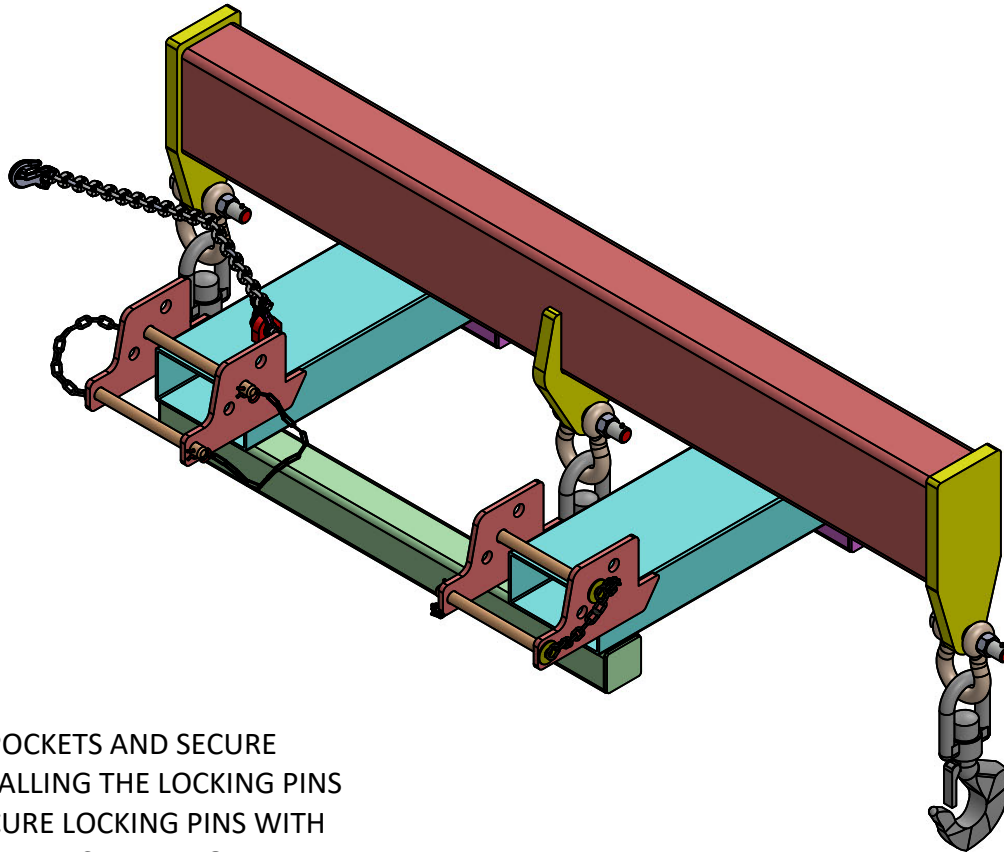

# 1149-FPA1B



**INSTALLATION:**  
 INSERT FORKS FULLY INTO FORK POCKETS AND SECURE SPREADER BAR TO FORKS BY INSTALLING THE LOCKING PINS BEHIND HEEL OF EACH FORK. SECURE LOCKING PINS WITH HAIR PINS. IN ADDITION WRAP SAFETY CHAIN AROUND A STRONG PART OF CARRIAGE TAKING UP THE SLACK, SECURE BY HOOKING LOCKING GRAB HOOK ONTO CHAIN

**PROPRIETARY AND CONFIDENTIAL**  
 THE INFORMATION CONTAINED IN THIS DRAWING IS THE SOLE PROPERTY OF STAR INDUSTRIES. ANY REPRODUCTION IN PART OR AS A WHOLE WITHOUT THE WRITTEN PERMISSION OF STAR INDUSTRIES IS PROHIBITED.

UNLESS OTHERWISE SPECIFIED:	NAME	DATE
DIMENSIONS ARE IN INCHES TOLERANCES: $\pm 1/16$ FRACTIONAL $\pm$ ANGULAR: MACH $\pm$ BEND $\pm$ TWO PLACE DECIMAL $\pm$ THREE PLACE DECIMAL $\pm$	DRAWN HI-TECH	4/30/2019
INTERPRET GEOMETRIC TOLERANCING PER:	CHECKED	
MATERIAL REFER PARTS DETAILS	ENG APPR.	
FINISH	MFG APPR.	
DO NOT SCALE DRAWING	Q.A.	
	COMMENTS:	

 <b>STAR INDUSTRIES</b>		
TITLE: <b>1149-FPA1B</b>		
SIZE <b>A</b>	DWG. NO. 1149-FPA1B-DLR	REV <b>0</b>
SCALE: 1:15	WEIGHT: 780.44 LBS	SHEET 1 OF 2

# 1149-FPA1B

ACCEPTS FORKS UP TO 8" WIDE X 3.5" THICK

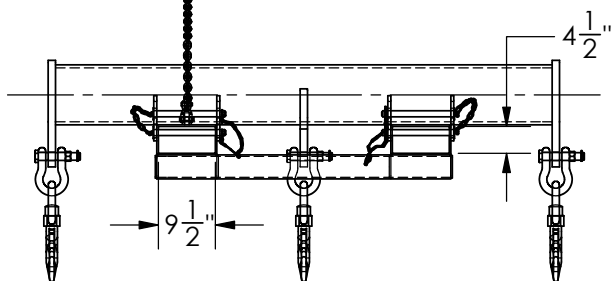
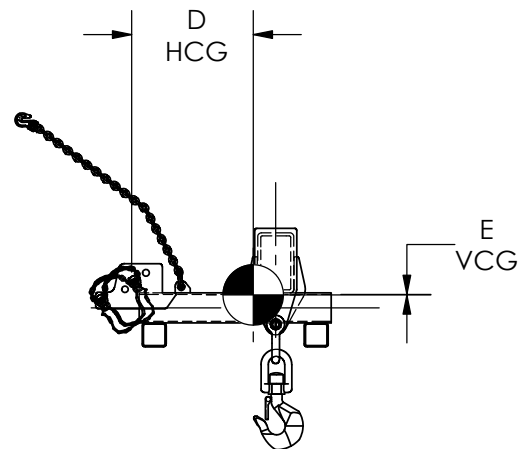
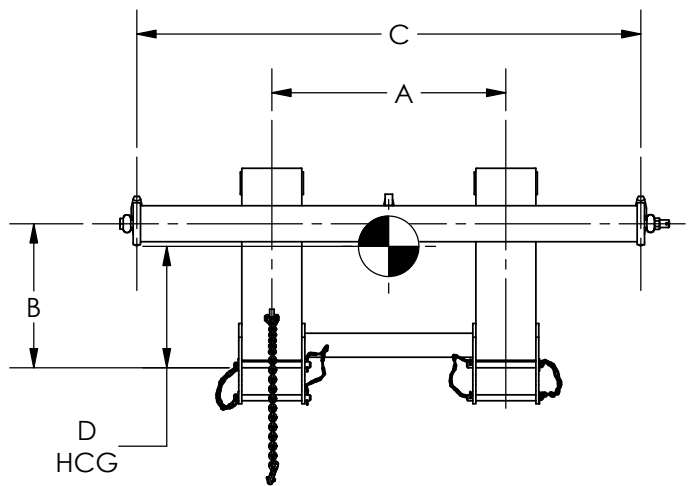

NOTE: CG IS MEASURED FROM TOP OF FORK BLADE AND FROM FACE OF FORK UPRIGHT

Model Numbers	A	B	C	D	E	Max Load - Lbs.		Bolted Shackles	Swivel Hooks w/ Latches
						Center Hook Used Alone	Using Two End Hooks or All 3 Hooks		
1149-FPA1B	39"	24"	84"	20 1/4"	1/8"	20,000	34,000	1 1/4" -12Ton	11 ton

SIZE <b>A</b>	DWG. NO. 1149-FPA1B-DLR	REV <b>0</b>
SCALE: 1:32	WEIGHT: 780.44 LBS	SHEET 2 OF 2